

1 2 3 4 5 6 7 8

REVISIONS				
ZONE	REV	DESCRIPTION	DATE	APPROVED

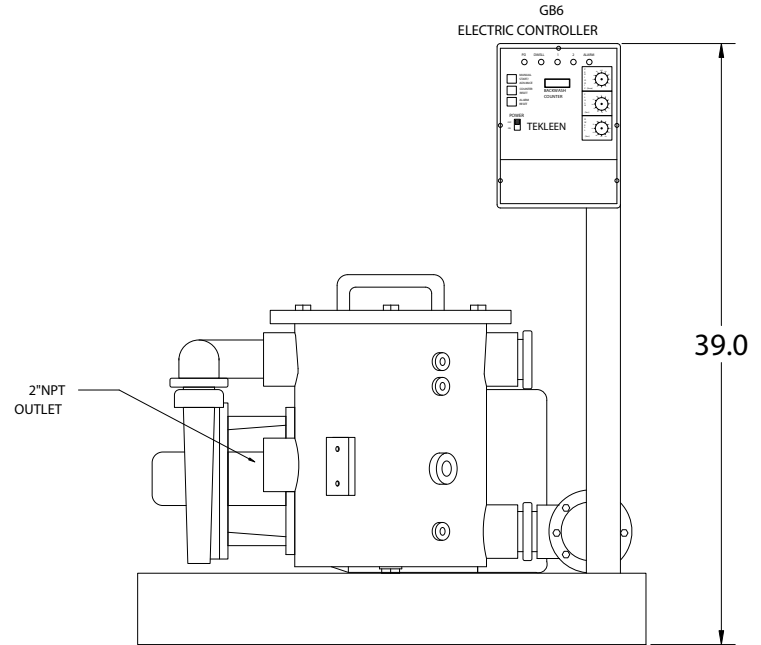
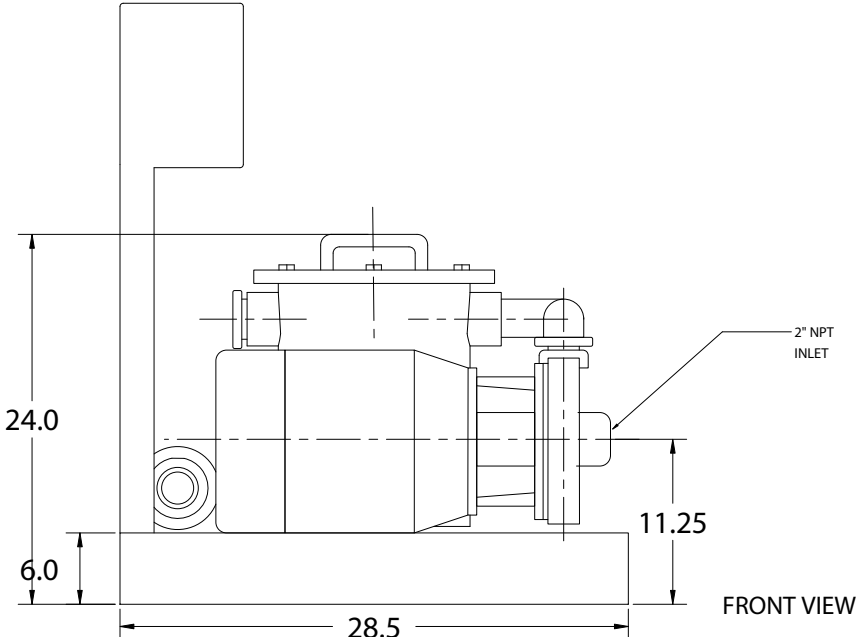
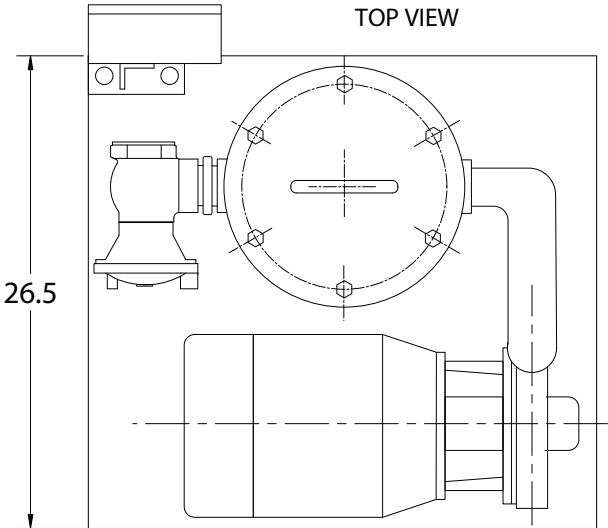

**FLOWRATE: MAX 130GPM**  
**MAX. PRESS: 150PSI**  
**PUMP POWER: 10HP**  
**WEIGHT: 200LBS**

UNLESS OTHERWISE SPECIFIED DIMENSIONS ARE IN INCHES TOLERANCES DECIMALS ANGULAR .XX + .05 ± 0.5 DEG. .XXX + .01		<b>AUTOMATIC FILTERS, INC.</b> 2672 S. LA CIENEGA BLVD. LOS ANGELES, CA 90034 (310) 839-2828 FAX (310) 839-6878	
DRAWN	DATE	TITLE	
DMITRIY POLISHCHUK	9-12-03	<b>ABW2-LP SKID UNIT</b>	
CHECKED		SIZE	REV
DESIGN		A	0
SCALE 1:6		SHEET OF	

E  
D  
C  
B  
A