

REVISIONS				
ZONE	REV	DESCRIPTION	DATE	APPROVED

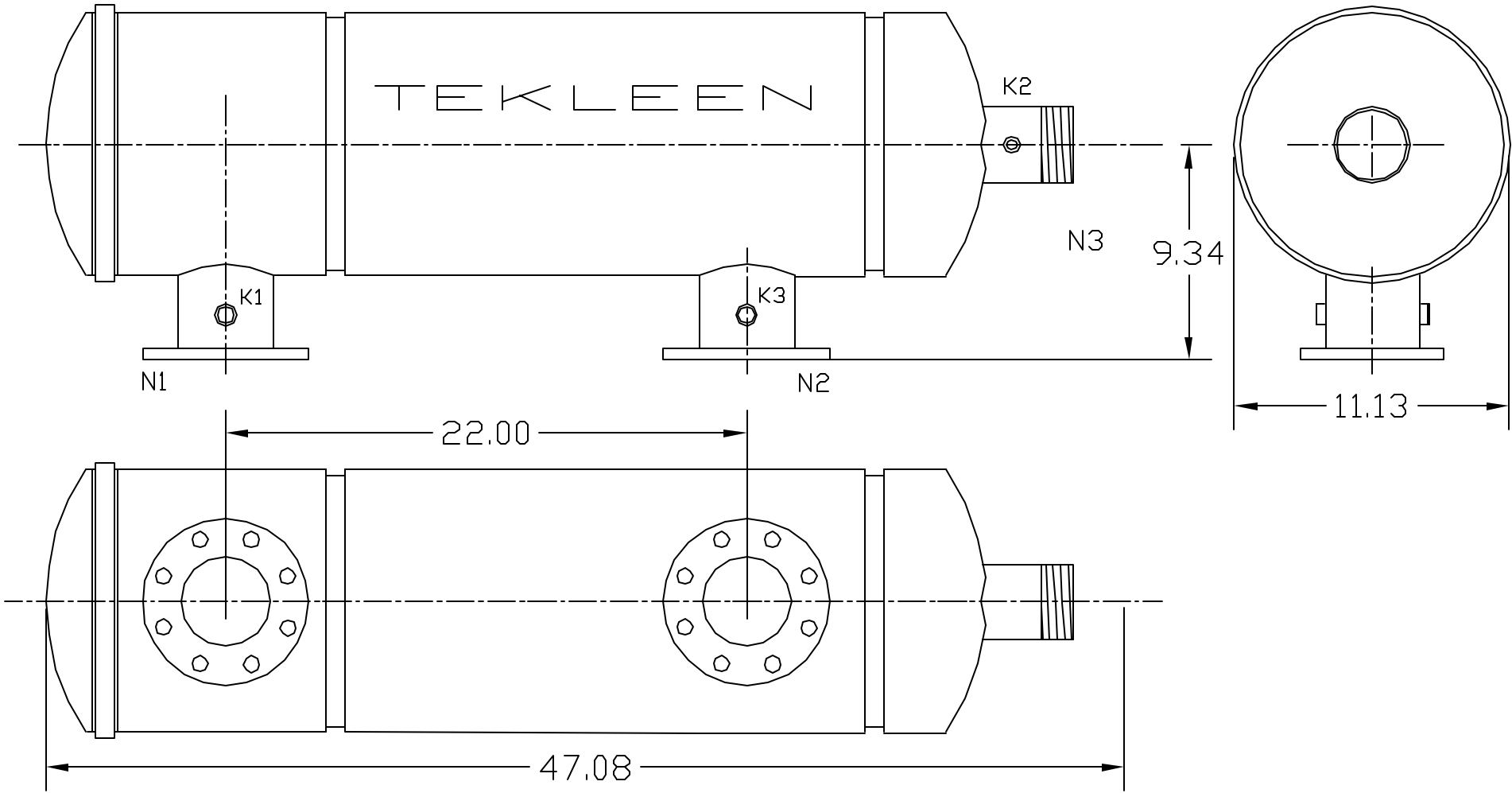

NOZZLE	CONNECTION	TYPE	SIZE
N1	INLET	FLANGED	4" ASA
N2	OUTLET	FLANGED	4" ASA
N3	FLUSH OUTLET	THREADED	2" NPT
K1	Hi Pres. Conn.	THREADED	1/4" NPT
K2	Back Wash	THREADED	1/8" NPT
K3	Low Pressure	THREADED	1/4" NPT

FLOWRATE: MAX. 500 GPM
 MAX. PRESS.: 125 PSI
 SCREEN SIZE: 10-400 MICRON
 SCREEN AREA: 3.0 SQ.FT.
 MAX. TEMP: 140 F (AVAIL. TO 210 F)
 WEIGHT: 90 LBS

UNLESS OTHERWISE SPECIFIED DIMENSIONS ARE IN INCHES TOLERANCES DECIMALS ANGULAR XX ± .05 ± 0.5 DEG. XXX ± .01		AUTOMATIC FILTERS, INC. 2672 S. LA CIENEGA BLVD. LOS ANGELES, CA 90034 (310) 839-2828 FAX (310) 839-6878		
		TITLE □BF4-P FLANGED Stainless Steel		
DRAWN Daniel Stenberg	DATE 6-2-05	SIZE A	DWG NO. □BF4-P	REV 1
CHECKED	DESIGN	NTS		SHEET 1 OF 1