

REVISIONS				
ZONE	REV	DESCRIPTION	DATE	APPROVED

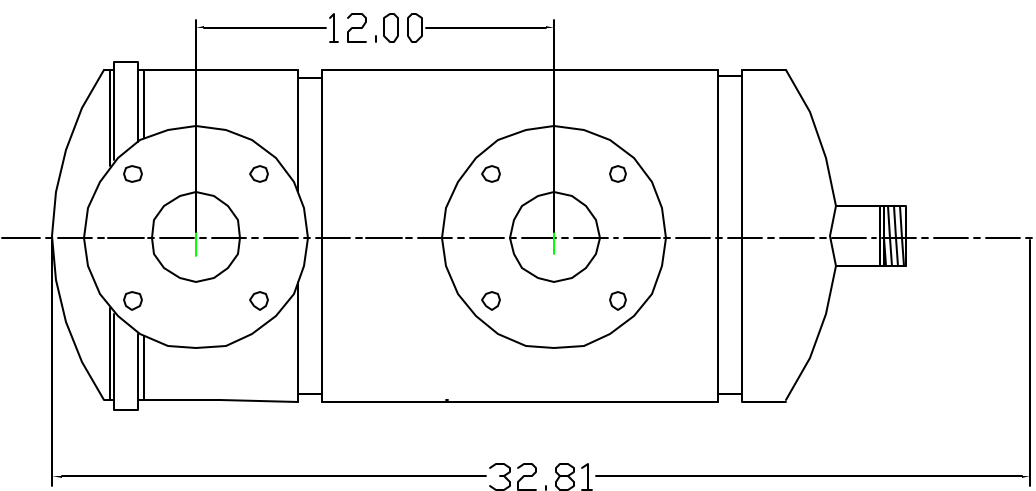
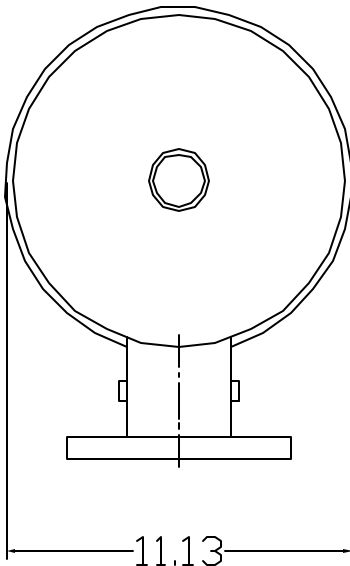
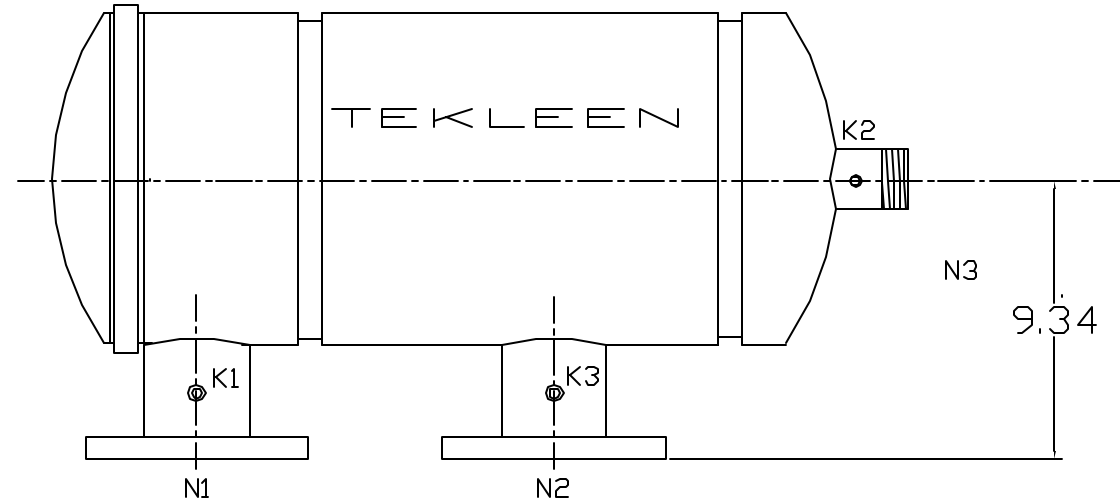

NOZZLE	CONNECTION	TYPE	SIZE
N1	INLET	FLANGED	3" ASA
N2	OUTLET	FLANGED	3" ASA
N3	FLUSH OUTLET	THREADED	2" NPT
K1	HI Pres. Conn.	THREADED	1/4" NPT
K2	BackWash P.	THREADED	1/8" NPT
K3	Low Pres.	THREADED	1/4" NPT

FLOWRATE: MAX. 250 GPM  
 MAX. PRESS.: 125 PSI  
 SCREEN SIZE: 5-400 MICRON  
 SCREEN AREA: 1.5 SQ.FT.  
 MAX. TEMP: 140 F (AVAIL. TO 210 F)  
 WEIGHT: 75 LBS

UNLESS OTHERWISE SPECIFIED DIMENSIONS ARE IN INCHES TOLERANCES DECIMALS    ANGULAR XX ± .05    ± 0.5 DEG. XXX ± .01		AUTOMATIC FILTERS, INC. 2672 S. LA CIENEGA BLVD. LOS ANGELES, CA 90034 (310) 839-2828 FAX (310) 839-6878	
DRAWN Daniel Stenberg		DATE 6-2-06	
CHECKED		TITLE OBF3-P FLANGED Stainless Steel	
DESIGN		SIZE A	DWG NO. OBF3-P
		NTS	REV 1 SHEET 1 OF 1