

1 2 3 4 5 6 7 8

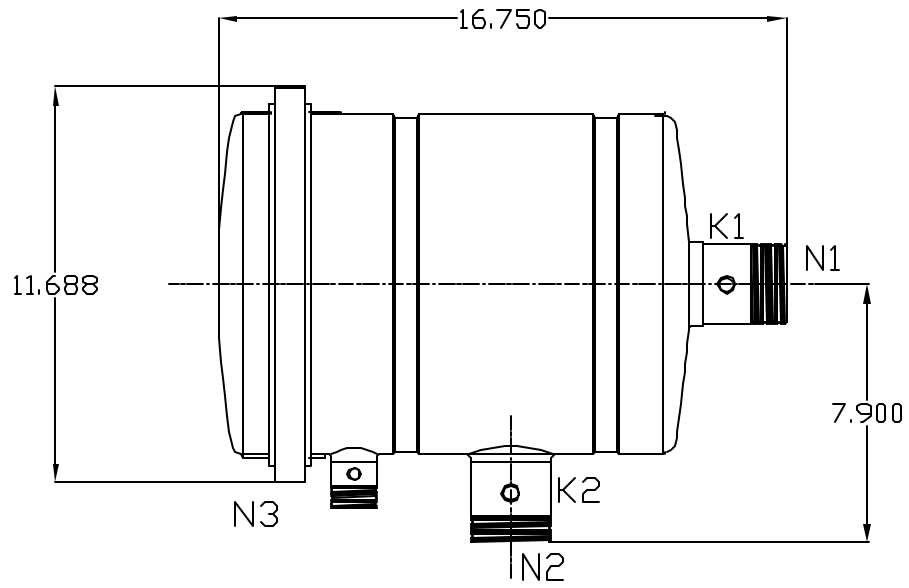

REVISIONS				
ZONE	REV	DESCRIPTION	DATE	APPROVED

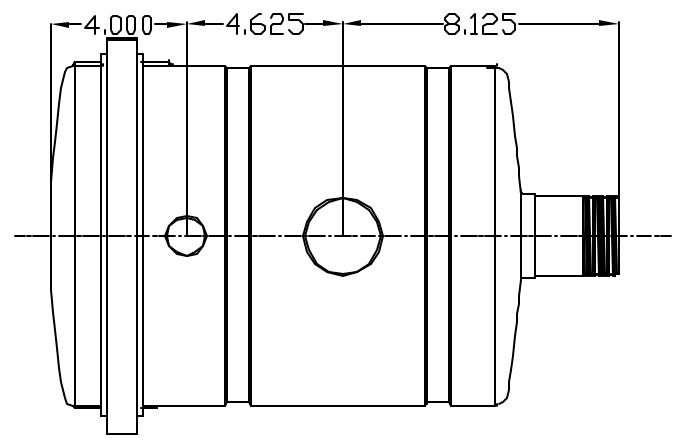
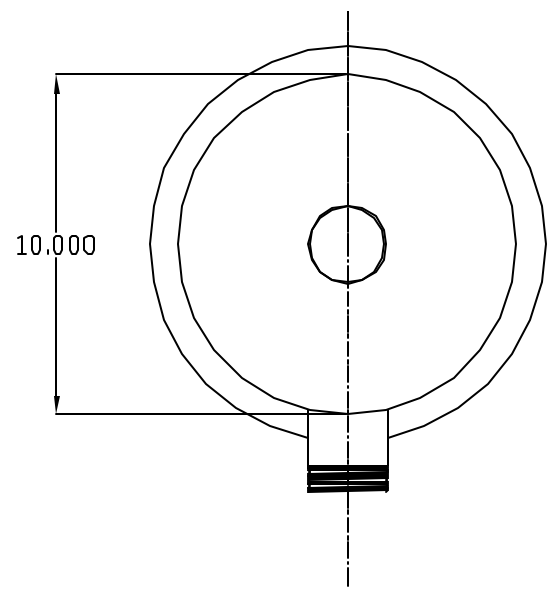

NOZZLE	CONNECTION	TYPE	SIZE
N1	INLET	THREADED	2" NPT
N2	OUTLET	THREADED	2" NPT
N3	FLUSH OUTLET	THREADED	1" NPT
K1	HI Pres. Conn.	THREADED	1/4" NPT
K2	Low Pres.	THREADED	1/4" NPT

FLOWRATE: MAX. 125 GPM
MAX. PRESS.: 125 PSI
SCREEN SIZE: 10-400 MICRON
SCREEN AREA: 0.8 SQ.FT.
MAX. TEMP.: 140 F (AVAIL. TO 210 F)
WEIGHT: 50 LBS

UNLESS OTHERWISE SPECIFIED
DIMENSIONS ARE IN INCHES

TOLERANCES

DECIMALS ANGULAR

.XX ± .05 ± 0.5 DEG.

.XXX ± .01

DRAWN	DATE
Daniel Stenberg	6-2-05
CHECKED	
DESIGN	

AUTOMATIC FILTERS, INC.
2672 S. LA CIENEGA BLVD.
LOS ANGELES, CA 90034
(310) 839-2828 FAX (310) 839-6878

TITLE

OBF 2

SIZE	DWG NO.	REV
A	OBF 2	1
NTS		SHEET OF

E
D
C
B
A