

REVISIONS				
ZONE	REV	DESCRIPTION	DATE	APPROVED

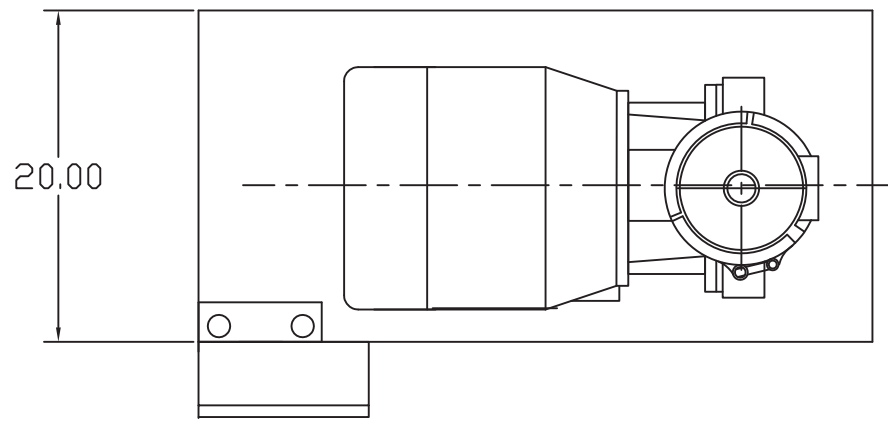
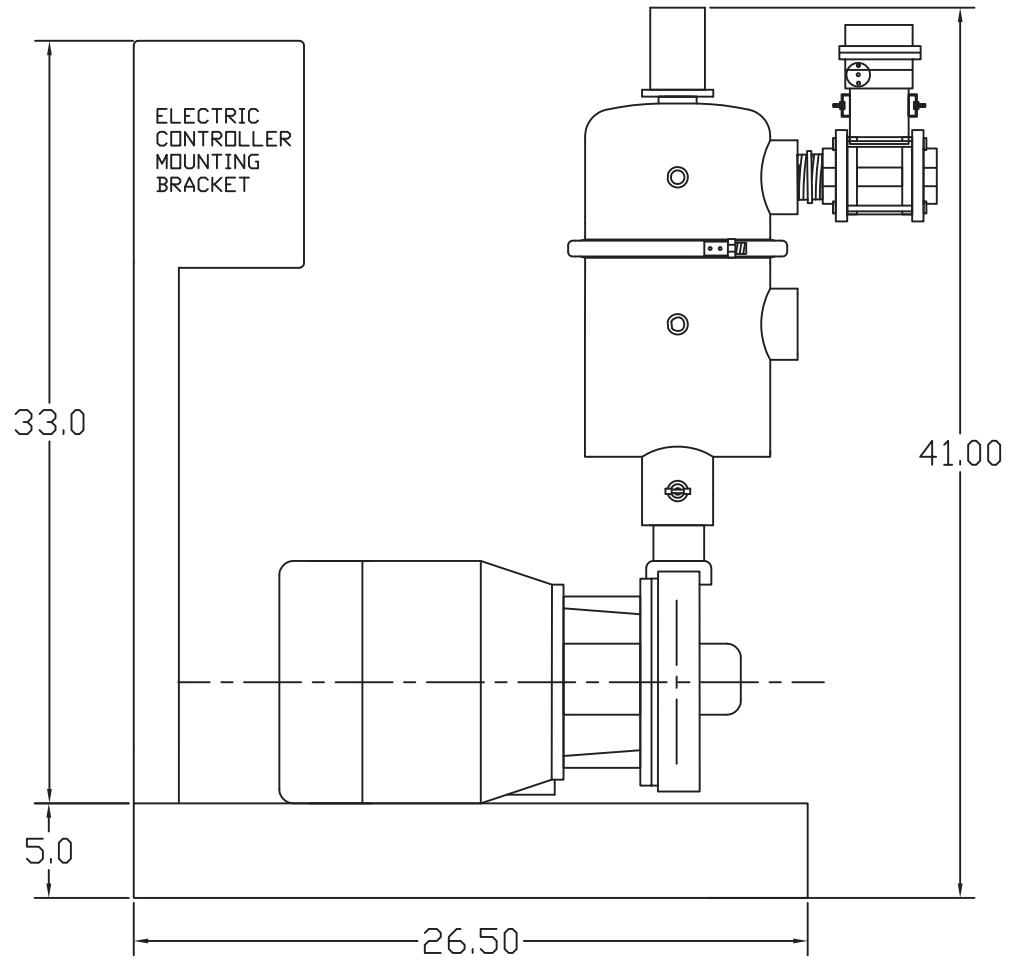

FLOWRATE: MAX. 200GPM  
 DESIGN PRESS: 150PSI  
 DESIGN TEMP: 160°F  
 PUMP POWER: 5HP  
 WEIGHT: 200LBS

UNLESS OTHERWISE SPECIFIED DIMENSIONS ARE IN INCHES TOLERANCES		AUTOMATIC FILTERS, INC. 2672 S. LA CIENEGA BLVD. LOS ANGELES, CA 90034 (310) 839-2828 FAX (310) 839-6878		
DECIMALS	ANGULAR	TITLE	MTF2L FILTER W/ EBV, GB6, AND ELECTRIC MOTOR MOUNTED ON SKID UNIT	
.XX ± .05	± 0.5 DEG.	SIZE	DWG NO.	REV
.XXX ± .01		A	SKID-MTF2L-CUT-01	N/A
DRAWN	DATE	Not To Scale		
JORDEN KAWAMOTO	01/28/14	SHEET OF		
CHECKED				
DESIGN				