

REVISIONS				
ZONE	REV	DESCRIPTION	DATE	APPROVED

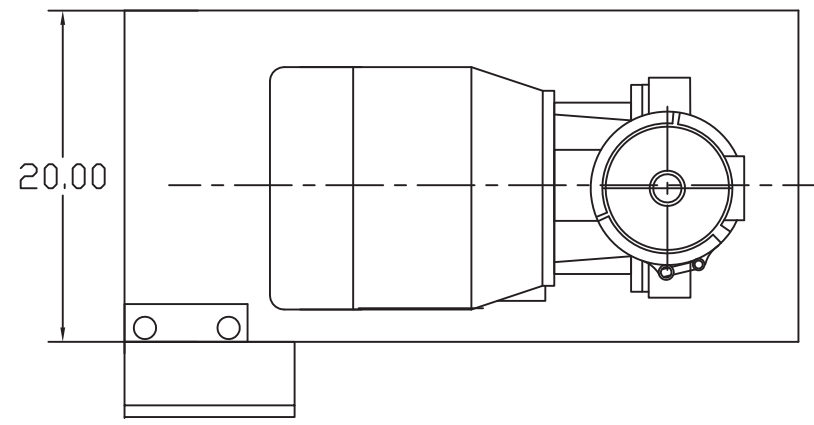
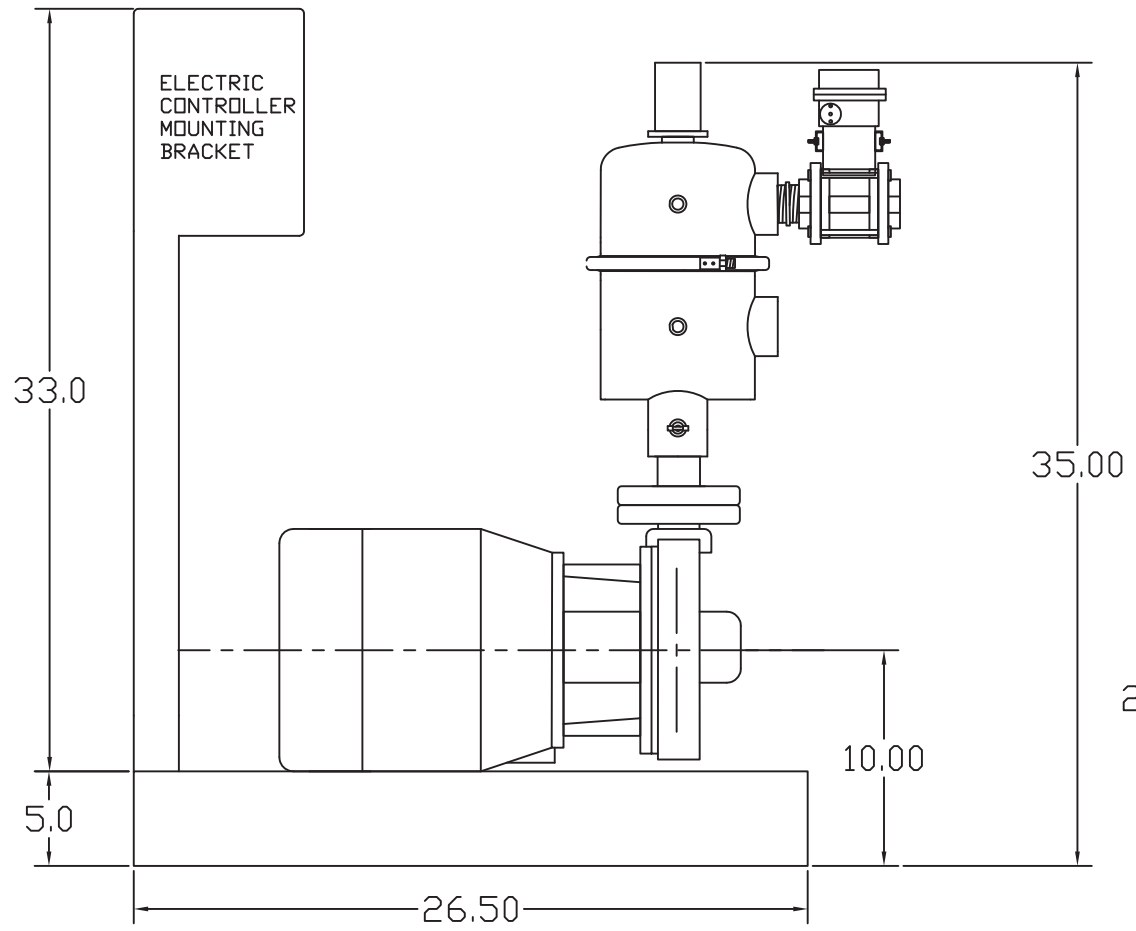

FLOWRATE: MAX 100GPM  
 DESIGN PRESS: 150PSI  
 DESIGN TEMP: 160°F  
 PUMP POWER: 3HP  
 WEIGHT: 150LBS

UNLESS OTHERWISE SPECIFIED DIMENSIONS ARE IN INCHES TOLERANCES		AUTOMATIC FILTERS, INC. 2672 S. LA CIENEGA BLVD. LOS ANGELES, CA 90034 (310) 839-2828 FAX (310) 839-6878		
DECIMALS	ANGULAR	TITLE		REV
.XX ± .05	± 0.5 DEG.	MTF2 FILTER W/ EBV, GB6, AND ELECTRIC MOTOR MOUNTED ON SKID UNIT		N/A
.XXX ± .01		SIZE	DWG NO.	
		A	SKID-MTF2-CUT-01	
DRAWN	DATE	SCALE 1:6		
JORDEN KAWAMOTO	05/13/13	SHEET OF		
CHECKED				
DESIGN				