

REVISIONS				
REV.	ZONE	DESCRIPTION	DATE	INITIAL
3	ALL	ROTATED FLANGE HOLES TO STRADDLE CENTERLINES, CHANGED "WORKING" TO DESIGN, AND TEMPERATURE FROM 200 TO 160 IN THE TECHNICAL DATA TABLE.	03/21/13	S.P.

REVISIONS				
REV.	ZONE	DESCRIPTION	DATE	INITIAL
1	ALL	INCREASED CENTER-TO-OUTLET PIPE LENGTH TO 15.7" & REDUCED OUTLET CENTER HEIGHT TO 23.6".	06/08/11	S.P.
2	3B	CHANGED MAX. FLOW RATE FROM 1,700 TO 2,400 GPM.	06/10/11	S.P.

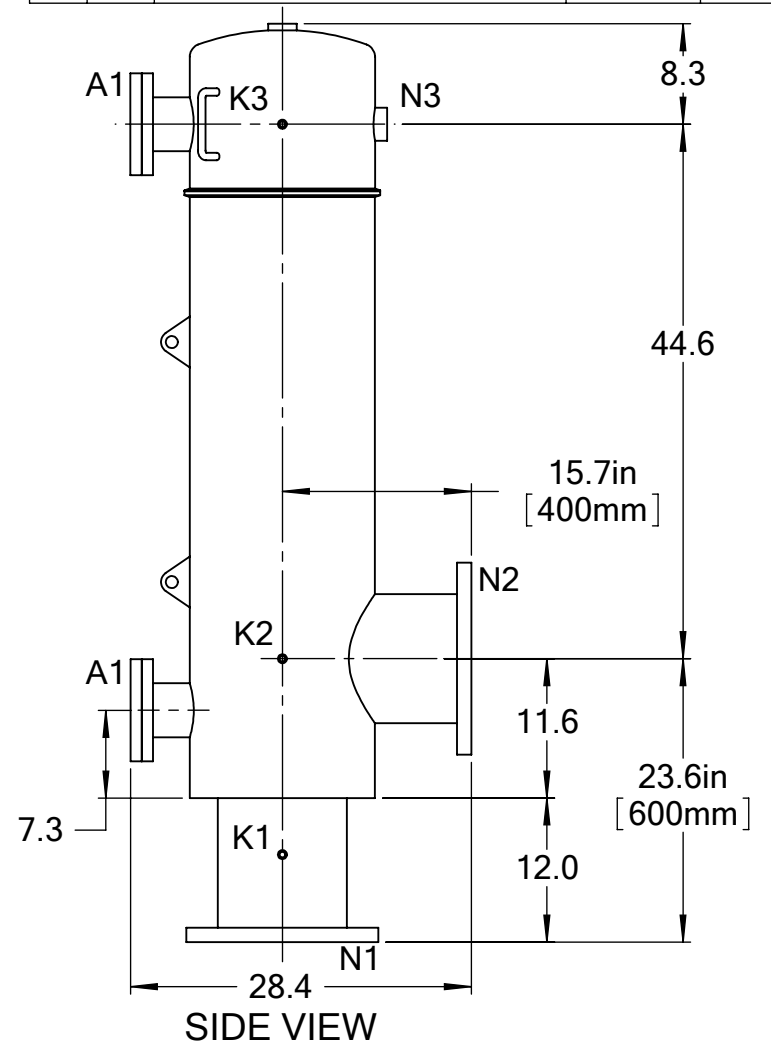
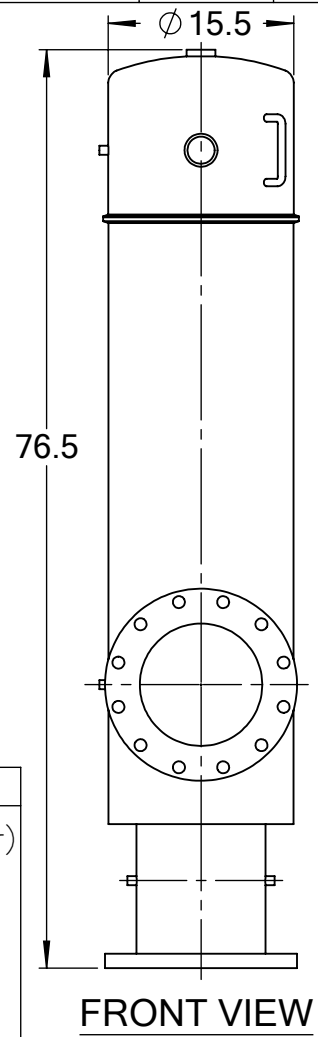

TECHNICAL DATA

FLOW RATE	MAX. 2,400 GPM (545 m ³ /hr)
SCREEN SIZE	____ MICRON
SCREEN AREA	11.0 SQ. FEET
DESIGN TEMPERATURE	MAX. 160 °F
DESIGN PRESSURE	MAX. 150 PSI
EMPTY WEIGHT	~500 LBS.
FULL WEIGHT	~1,000 LBS.

NOZZLE	CONNECTION	TYPE	SIZE	RATING
A1	SERVICE PORT	FLANGED	3.5" ASA(2)	CL. #150 F.F. w/ Blind
K1	HIGH PRESSURE CONN.	THREADED	1/4" NPT(2)	
K2	LOW PRESSURE CONN.	THREADED	1/4" NPT	CLASS #150 F.F.S.O. CLASS #150 F.F.S.O.
K3	HYDRAULIC CONN.	THREADED	1/4" NPT	
N1	INLET	FLANGED	10" ASA	
N2	OUTLET	FLANGED	10" ASA	
N3	FLUSH OUTLET	THREADED	2" NPT	

**TOLERANCES
(UNLESS OTHERWISE SPECIFIED)**

FRAC. ±1/16
.X ±.1
.XX ±.05
.XXX ±.010

ANGLE ±1°

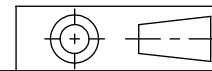

MATERIAL: SST

DRAWN BY: S. PERKINSON

DATE: 05/26/11

SCALE: 1:16

SHEET: 1 OF 1

TEKLEEN®
Automatic Filters Inc.

2672 S. LA CIENEGA BLVD.
LOS ANGELES, CA 90034
MAIN: (310) 839-2828
FAX: (310) 839-6878

TITLE:
MTF10-L FILTER,
CUT DRAWING

DRAWING NUMBER	REV
MTF-10L-CUT-01	3