

REVISIONS				
REV.	ZONE	DESCRIPTION	DATE	INITIAL
1	7D	ADDED NOTE 1.	04/16/15	M.S.

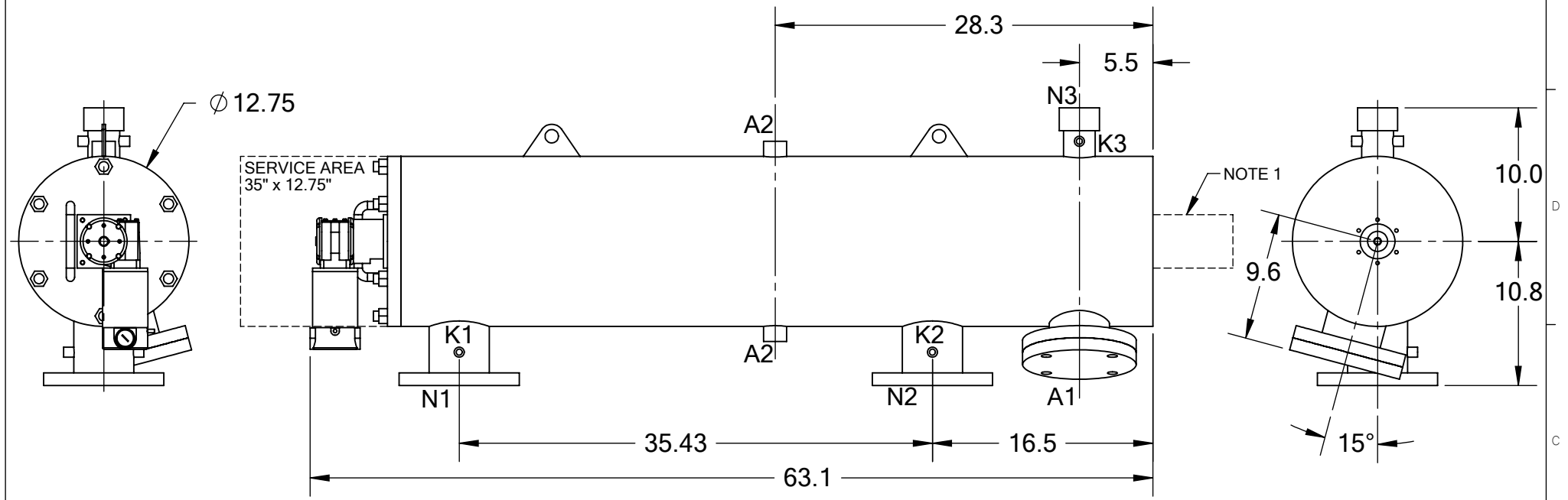

TECHNICAL DATA

FLOW RATE	MAX. 600 GPM (136 m <sup>3</sup> /hr)
SCREEN SIZE	___ MICRON
SCREEN AREA	5.0 SQ. FEET
DESIGN TEMPERATURE	160 °F
DESIGN PRESSURE	150 PSI
EMPTY WEIGHT	~280 LBS.
FULL WEIGHT	~480 LBS.

NOTES:  
 1. PLEASE ALLOW ~20" ADDITIONAL TO INSTALL AND REMOVE THE PISTON ASSEMBLY TO THE BACKSIDE OF THE FILTER.

NOZZLE	CONNECTION	TYPE	SIZE	RATING
A1	SERVICE PORT	FLANGED	3.5" ASA	CL. #150 F.F. w/ Blind
A2	PRESSURE RELEASE	THREADED	1" NPT(2)	
K1	HIGH PRESSURE CONN.	THREADED	1/4" NPT(2)	CLASS #150 F.F.S.O.
K2	LOW PRESSURE CONN.	THREADED	1/4" NPT(2)	
K3	HYDRAULIC CONN.	THREADED	1/4" NPT(2)	CLASS #150 F.F.S.O.
N1	INLET	FLANGED	4" ASA	
N2	OUTLET	FLANGED	4" ASA	
N3	FLUSH OUTLET	THREADED	2" NPT	

TOLERANCES (UNLESS OTHERWISE SPECIFIED)	
FRAC. ±1/16	ANGLE ±1°
.X ±.1	
.XX ±.05	
.XXX ±.010	
MATERIAL: SST	
DRAWN BY: S. PERKINSON	
DATE: 04/11/12	
SCALE: 1:11	SHEET: 1 OF 1

**TEKLEEN**  
 Automatic Filters Inc.  
 2672 S. LA CIENEGA BLVD.  
 LOS ANGELES, CA 90034  
 MAIN: (310) 839-2828  
 FAX: (310) 839-6878

TITLE:  
 LPF4-LP FILTER,  
 CUT DRAWING

DRAWING NUMBER	REV
LPF-4LP-CUT-01	1