

REVISIONS				
REV.	ZONE	DESCRIPTION	DATE	INITIAL
1	7D	ADDED NOTE 1.	04/21/15	M.S.

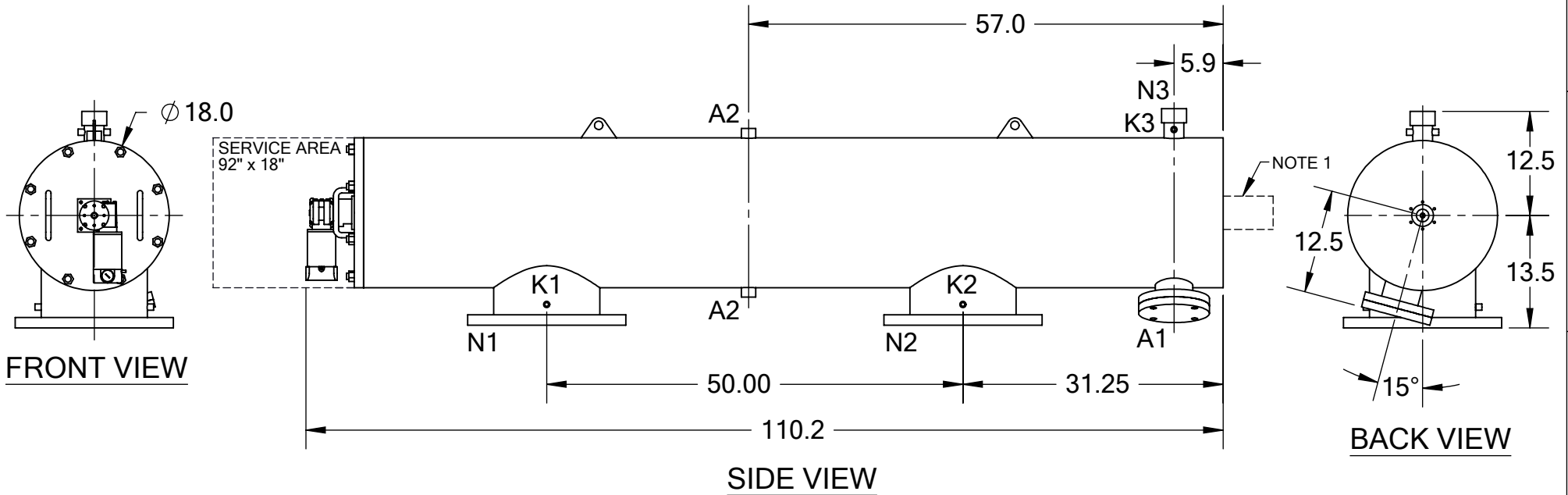

TECHNICAL DATA

FLOW RATE	MAX. 4,000 GPM (908 m ³ /hr)
SCREEN SIZE	___ MICRON
SCREEN AREA	12.5 SQ. FEET
DESIGN TEMPERATURE	160 °F
DESIGN PRESSURE	150 PSI
EMPTY WEIGHT	~850 LBS.
FULL WEIGHT	~1,300 LBS.

NOTES:

- PLEASE ALLOW ~20" ADDITIONAL TO INSTALL AND REMOVE THE PISTON ASSEMBLY TO THE BACKSIDE OF THE FILTER.

NOZZLE	CONNECTION	TYPE	SIZE	RATING	TOLERANCES (UNLESS OTHERWISE SPECIFIED)		 2672 S. LA CIENEGA BLVD. LOS ANGELES, CA 90034 MAIN: (310) 839-2828 FAX: (310) 839-6878
A1	SERVICE PORT	FLANGED	3.5" ASA	CL. #150 F.F. w/ Blind	FRAC. ±1/16	ANGLE ±1°	
A2	PRESSURE RELEASE	THREADED	1" NPT(2)		.X ±.1		
K1	HIGH PRESSURE CONN.	THREADED	1/4" NPT(2)	CLASS #150 F.F.S.O.	.XX ±.05	TITLE: LPF12-LP FILTER, CUT DRAWING	
K2	LOW PRESSURE CONN.	THREADED	1/4" NPT(2)		.XXX ±.010		
K3	HYDRAULIC CONN.	THREADED	1/4" NPT(2)	CLASS #150 F.F.S.O.	MATERIAL: SST		DRAWING NUMBER
N1	INLET	FLANGED	12" ASA		DRAWN BY: S. PERKINSON		
N2	OUTLET	FLANGED	12" ASA	DATE: 04/24/12		LPF-12LP-CUT-01	
N3	FLUSH OUTLET	THREADED	2" NPT	SCALE: 1:18		SHEET: 1 OF 1	