

REVISIONS				
REV.	ZONE	DESCRIPTION	DATE	INITIAL

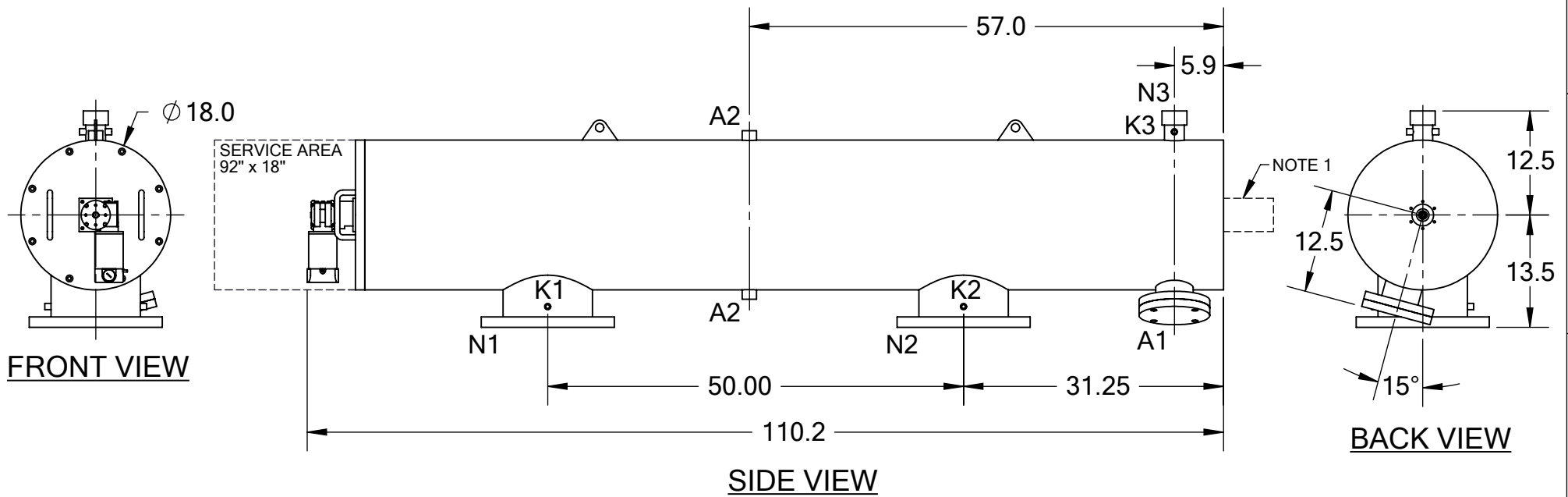

**TECHNICAL DATA**

FLOW RATE	MAX. 4,000 GPM (908 m <sup>3</sup> /hr)
SCREEN SIZE	___ MICRON
SCREEN AREA	12.5 SQ. FEET
DESIGN TEMPERATURE	160 °F
DESIGN PRESSURE	150 PSI
EMPTY WEIGHT	~825 LBS.
FULL WEIGHT	~1,275 LBS.

**NOTES:**

- PLEASE ALLOW ~20" ADDITIONAL TO INSTALL AND REMOVE THE PISTON ASSEMBLY TO THE BACKSIDE OF THE FILTER.

NOZZLE	CONNECTION	TYPE	SIZE	RATING
A1	SERVICE PORT	FLANGED	3.5" ASA	CL. #150 F.F. w/ Blind
A2	PRESSURE RELEASE	THREADED	1" NPT(2)	
K1	HIGH PRESSURE CONN.	THREADED	1/4" NPT(2)	CLASS #150 F.F.S.O.
K2	LOW PRESSURE CONN.	THREADED	1/4" NPT(2)	
K3	HYDRAULIC CONN.	THREADED	1/4" NPT(2)	CLASS #150 F.F.S.O.
N1	INLET	FLANGED	10" ASA	
N2	OUTLET	FLANGED	10" ASA	
N3	FLUSH OUTLET	THREADED	2" NPT	

**TOLERANCES (UNLESS OTHERWISE SPECIFIED)**

FRAC. ±1/16	ANGLE ±1°
.X ±.1	
.XX ±.05	
.XXX ±.010	

<b>MATERIAL:</b> SST
<b>DRAWN BY:</b> M. SERRANO
<b>DATE:</b> 11/15/18
<b>SCALE:</b> 1:18
<b>SHEET:</b> 1 OF 1

**TEKLEEN**  
Automatic Filters Inc.  
2672 S. LA CIENEGA BLVD.  
LOS ANGELES, CA 90034  
MAIN: (310) 839-2828  
FAX: (310) 839-6878

<b>TITLE:</b> LPF10-SLP FILTER, CUT DRAWING	
<b>DRAWING NUMBER</b> LPF-10SLP-CUT-01	<b>REV</b> N/A