

REVISIONS				
REV.	ZONE	DESCRIPTION	DATE	INITIAL
1	1B, 2B	CHANGED "WORKING" TO "DESIGN" & TEMPERATURE FROM 200°F TO 160°F IN TECHNICAL DATA TABLE.	09/27/12	S.P.
2	7D	ADDED NOTE 1.	10/17/14	M.S.

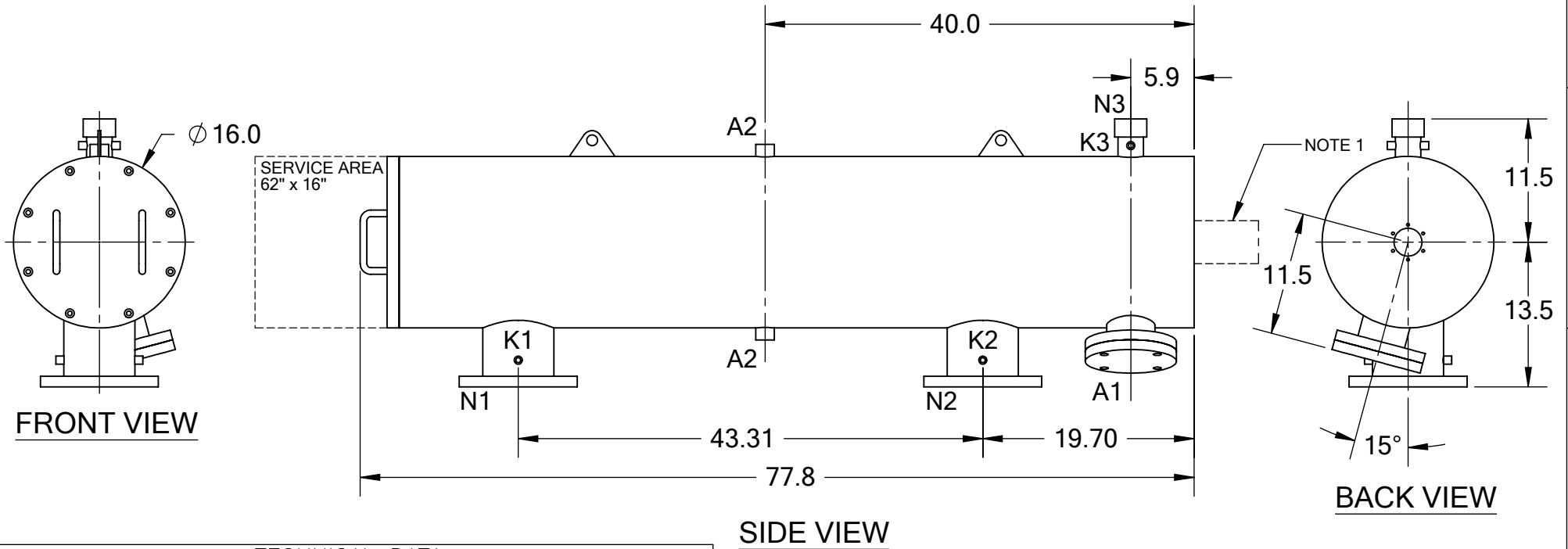

TECHNICAL DATA

FLOW RATE	MAX. 1,750 GPM (397 m ³ /hr)
SCREEN SIZE	____ MICRON
SCREEN AREA	7.0 SQ. FEET
DESIGN TEMPERATURE	160 °F
DESIGN PRESSURE	150 PSI
EMPTY WEIGHT	~535 LBS.
FULL WEIGHT	~1,060 LBS.

NOTES:

- PLEASE ALLOW ~20" ADDITIONAL TO INSTALL AND REMOVE THE PISTON ASSEMBLY TO THE BACKSIDE OF THE FILTER.

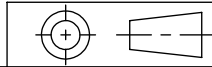
NOZZLE	CONNECTION	TYPE	SIZE	RATING	TOLERANCES (UNLESS OTHERWISE SPECIFIED)		 2672 S. LA CIENEGA BLVD. LOS ANGELES, CA 90034 MAIN: (310) 839-2828 FAX: (310) 839-6878
A1	SERVICE PORT	FLANGED	3.5" ASA	CL. #150 F.F. w/ Blind	FRAC. ±1/16	ANGLE ±1°	
A2	PRESSURE RELEASE	THREADED	1" NPT(2)		.X ±.1		
K1	HIGH PRESSURE CONN.	THREADED	1/4" NPT(2)	CLASS #150 F.F.S.O. CLASS #150 F.F.S.O.	.XX ±.05	MATERIAL: SST DRAWN BY: S. PERKINSON DATE: 06/28/11 SCALE: 1:14 SHEET: 1 OF 1	
K2	LOW PRESSURE CONN.	THREADED	1/4" NPT(2)		.XXX ±.010		
K3	HYDRAULIC CONN.	THREADED	1/4" NPT(2)				
N1	INLET	FLANGED	6" ASA		TITLE: ABW6-SP FILTER, CUT DRAWING		
N2	OUTLET	FLANGED	6" ASA		DRAWING NUMBER		
N3	FLUSH OUTLET	THREADED	2" NPT		ABW-6SP-CUT-01		
							REV
							2