

REVISIONS				
REV.	ZONE	DESCRIPTION	DATE	INITIAL
1	1B, 2B	CHANGED "WORKING" TO "DESIGN" & TEMPERATURE FROM 200°F TO 160°F IN TECHNICAL DATA TABLE.	09/27/12	S.P.
2	7D	ADDED NOTE 1.	10/17/14	M.S.

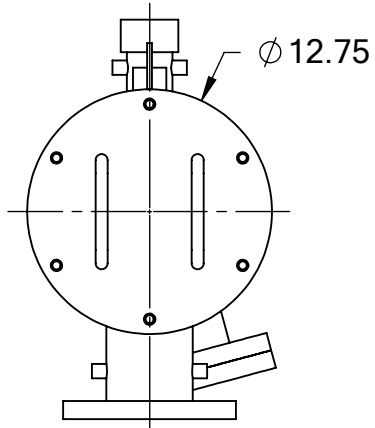

FRONT VIEW

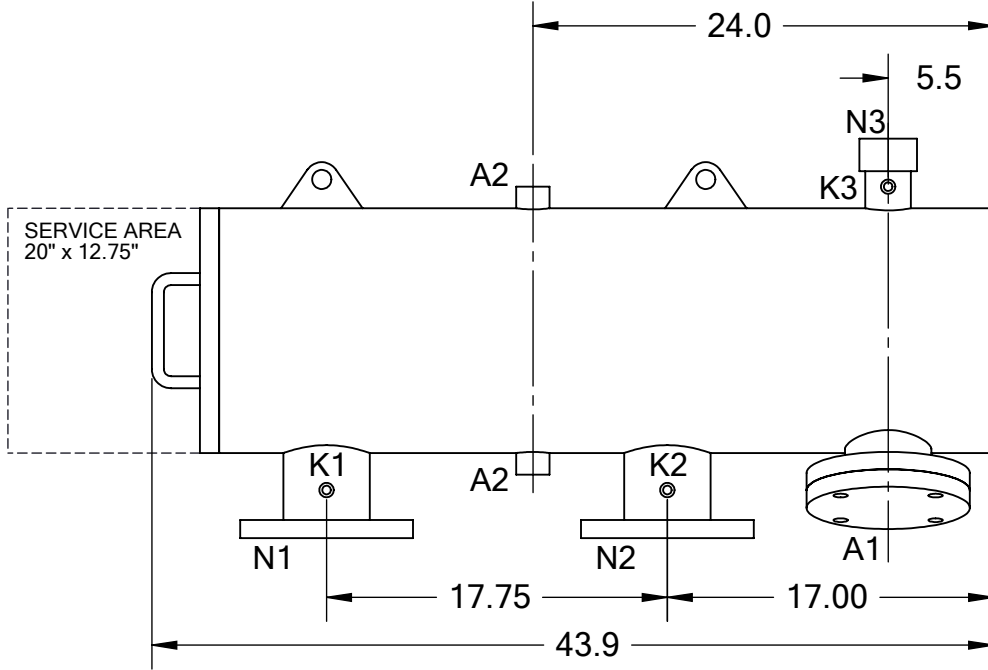

SIDE VIEW

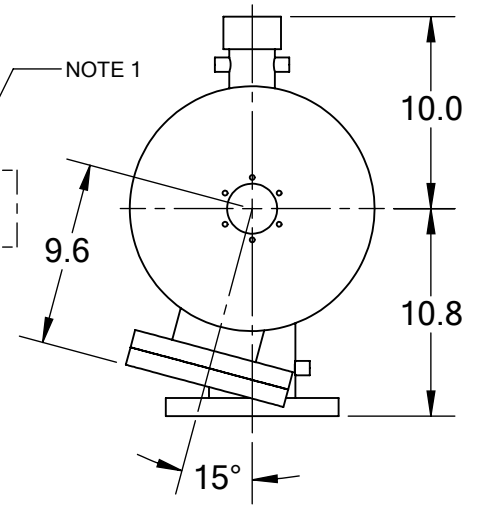

BACK VIEW

SERVICE AREA
20" x 12.75"

NOTE 1

TECHNICAL DATA

FLOW RATE	MAX. 400 GPM (91 m ³ /hr)
SCREEN SIZE	___ MICRON
SCREEN AREA	2.5 SQ. FEET
DESIGN TEMPERATURE	160 °F
DESIGN PRESSURE	150 PSI
EMPTY WEIGHT	~250 LBS.
FULL WEIGHT	~450 LBS.

NOTES:

- PLEASE ALLOW ~20" ADDITIONAL TO INSTALL AND REMOVE THE PISTON ASSEMBLY TO THE BACKSIDE OF THE FILTER.

NOZZLE	CONNECTION	TYPE	SIZE	RATING
A1	SERVICE PORT	FLANGED	3.5" ASA	CL. #150 F.F. w/ Blind
A2	PRESSURE RELEASE	THREADED	1" NPT(2)	
K1	HIGH PRESSURE CONN.	THREADED	1/4" NPT(2)	
K2	LOW PRESSURE CONN.	THREADED	1/4" NPT(2)	
K3	HYDRAULIC CONN.	THREADED	1/4" NPT(2)	
N1	INLET	FLANGED	4" ASA	
N2	OUTLET	FLANGED	4" ASA	CLASS #150 F.F.S.O.
N3	FLUSH OUTLET	THREADED	2" NPT	CLASS #150 F.F.S.O.

TOLERANCES (UNLESS OTHERWISE SPECIFIED)	
FRAC. ±1/16	ANGLE ±1°
.X ±.1	
.XX ±.05	
.XXX ±.010	
MATERIAL: SST	
DRAWN BY: S. PERKINSON	
DATE: 06/23/11	
SCALE: 1:10	SHEET: 1 OF 1

TEKLEEN
Automatic Filters Inc.
2672 S. LA CIENEGA BLVD.
LOS ANGELES, CA 90034
MAIN: (310) 839-2828
FAX: (310) 839-6878

TITLE:
ABW4-LPE FILTER,
CUT DRAWING

DRAWING NUMBER	REV
ABW-4LPE-CUT-01	2