

REVISIONS				
REV.	ZONE	DESCRIPTION	DATE	INITIAL
1	1B, 2B	CHANGED TEMPERATURE FROM 200°F TO 160°F, PRESSURE FROM 150 PSI TO 90 PSI, & WORDING FROM "WORKING" TO "DESIGN".	08/01/12	S.P.
2	7D	ADDED NOTE 1.	10/17/14	M.S.

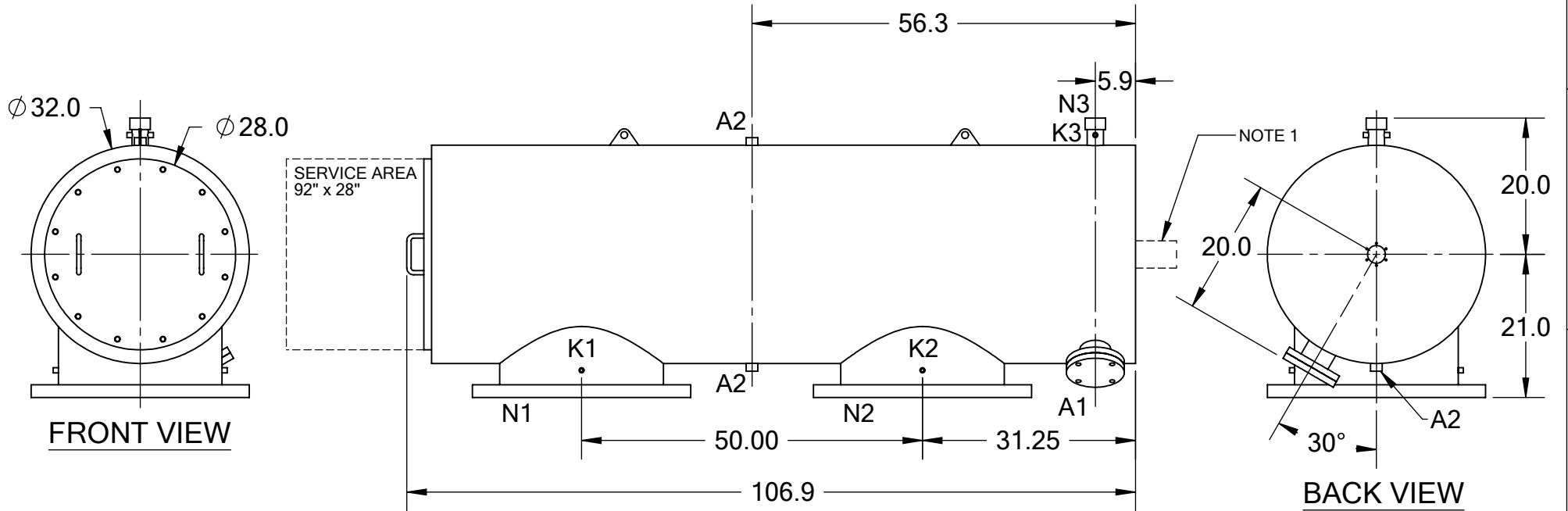

TECHNICAL DATA

FLOW RATE	MAX. 10,000 GPM (2,271 m ³ /hr)
SCREEN SIZE	____ MICRON
SCREEN AREA	24.0 SQ. FEET
DESIGN TEMPERATURE	160 °F
DESIGN PRESSURE	90 PSI
EMPTY WEIGHT	~2,500 LBS.
FULL WEIGHT	~5,500 LBS.

SIDE VIEW

NOTES:
 1. PLEASE ALLOW ~20" ADDITIONAL TO INSTALL AND REMOVE THE PISTON ASSEMBLY TO THE BACKSIDE OF THE FILTER.

NOZZLE	CONNECTION	TYPE	SIZE	RATING
A1	SERVICE PORT	FLANGED	3.5" ASA	CL. #150 F.F. w/ Blind
A2	PRESSURE RELEASE	THREADED	1" NPT(3)	
K1	HIGH PRESSURE CONN.	THREADED	1/4" NPT(2)	
K2	LOW PRESSURE CONN.	THREADED	1/4" NPT(2)	
K3	HYDRAULIC CONN.	THREADED	1/4" NPT(2)	
N1	INLET	FLANGED	24" ASA	
N2	OUTLET	FLANGED	24" ASA	CLASS #150 F.F.S.O.
N3	FLUSH OUTLET	THREADED	2" NPT	CLASS #150 F.F.S.O.

TOLERANCES (UNLESS OTHERWISE SPECIFIED)

FRAC. ±1/16	ANGLE ±1°
.X ±.1	
.XX ±.05	
.XXX ±.010	

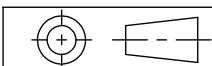

MATERIAL: SST
DRAWN BY: S. PERKINSON
DATE: 09/26/11
SCALE: 1:22
SHEET: 1 OF 1

TEKLEEN
 Automatic Filters Inc.
 2672 S. LA CIENEGA BLVD.
 LOS ANGELES, CA 90034
 MAIN: (310) 839-2828
 FAX: (310) 839-6878

TITLE: ABW24-SP FILTER, CUT DRAWING	
DRAWING NUMBER ABW-24SP-CUT-01	REV 2