

REVISIONS				
REV.	ZONE	DESCRIPTION	DATE	INITIAL

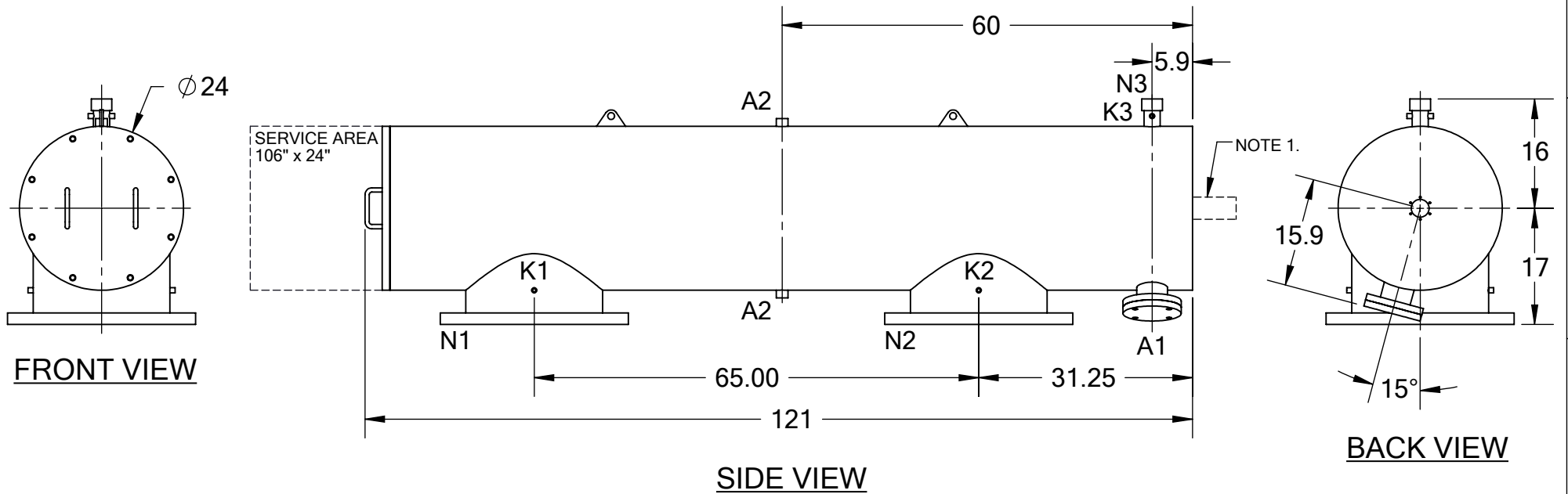

TECHNICAL DATA

FLOW RATE	8,000 GPM (1,817 m ³ /hr)
SCREEN SIZE	___ MICRON
SCREEN AREA	20.0 SQ. FEET
DESIGN TEMPERATURE	160 °F
DESIGN PRESSURE	150 PSI
EMPTY WEIGHT	~1,800 LBS.
FULL WEIGHT	~2,600 LBS.

NOTES:

- PLEASE ALLOW ~20" ADDITIONAL TO INSTALL AND REMOVE THE PISTON ASSEMBLY TO THE BACKSIDE OF THE FILTER

UNAUTHORIZED USE, MANUFACTURE OR REPRODUCTION IN WHOLE OR IN PART IS PROHIBITED. DRAWING, DESIGN AND OTHER DISCLOSURES PROPERTY OF TEKLEEN AUTOMATIC FILTERS, INC.

NOZZLE	CONNECTION	TYPE	SIZE	RATING	TOLERANCES (UNLESS OTHERWISE SPECIFIED)	 2672 S. LA CIENEGA BLVD. LOS ANGELES, CA 90034 MAIN: (310) 839-2828 FAX: (310) 839-6878
A1	SERVICE PORT	FLANGED	3.5" ASA	CL. #150 F.F. w/ Blind	FRAC. ±1/16	
A2	PRESSURE RELEASE	THREADED	1" NPT(2)		.X ±.1	
K1	HIGH PRESSURE CONN.	THREADED	1/4" NPT(2)		.XX ±.05	MATERIAL: SST
K2	LOW PRESSURE CONN.	THREADED	1/4" NPT(2)		.XXX ±.010	
K3	HYDRAULIC CONN.	THREADED	1/4" NPT(2)			TITLE: ABW20-XLP FILTER, CUT DRAWING
N1	INLET	FLANGED	20" ASA	CLASS #150 F.F.S.O.		
N2	OUTLET	FLANGED	20" ASA	CLASS #150 F.F.S.O.		DRAWING NUMBER REV ABW-20XLP-CUT-01 N/A
N3	FLUSH OUTLET	THREADED	2" NPT			
					DRAWN BY: M. SERRANO DATE: 05/17/2018 SCALE: 1:22	SHEET: 1 OF 1