

REVISIONS				
REV.	ZONE	DESCRIPTION	DATE	INITIAL

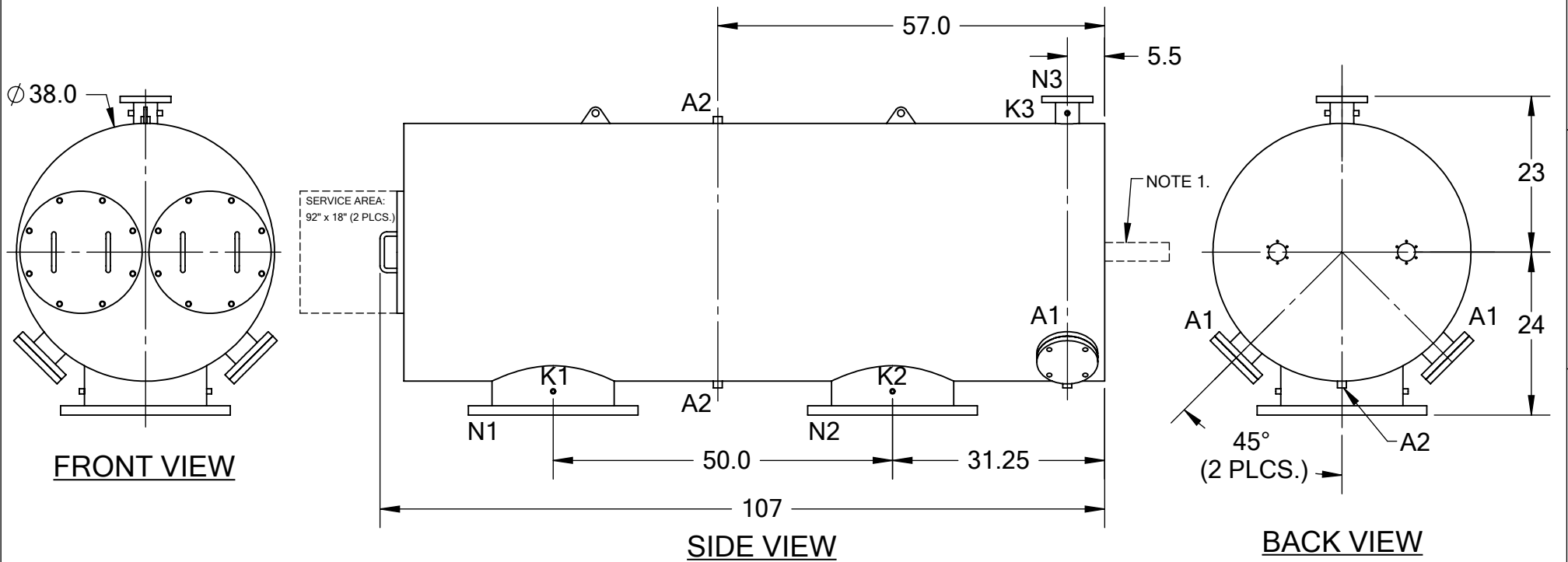

**TECHNICAL DATA**

FLOW RATE	8,000 GPM (1,817 m <sup>3</sup> /hr)
SCREEN SIZE	--- MICRON
SCREEN AREA	25.0 SQ. FT. (2 x 12.5 SQ. FT.)
DESIGN TEMPERATURE	160 °F
DESIGN PRESSURE	150 PSI
EMPTY WEIGHT	~3,000 LBS.
FULL WEIGHT	~8,000 LBS.

**NOTES:**

- PLEASE ALLOW ~20" ADDITIONAL TO INSTALL AND REMOVE THE PISTON ASSEMBLY TO THE BACKSIDE OF THE FILTER (2 PLCS.).
- SERVICE AREAS ARE NOT TO SCALE.

UNAUTHORIZED USE, MANUFACTURE OR REPRODUCTION IN WHOLE OR IN PART IS PROHIBITED. DRAWING, DESIGN AND OTHER DISCLOSURES PROPERTY OF TEKLEEN AUTOMATIC FILTERS, INC.

NOZZLE	CONNECTION	TYPE	SIZE	RATING
A1	SERVICE PORT	FLANGED	3.5" ASA(2)	CL. #150 F.F. w/ Blind
A2	PRESSURE RELEASE	THREADED	1" NPT(3)	
K1	HIGH PRESSURE CONN.	THREADED	1/4" NPT(2)	
K2	LOW PRESSURE CONN.	THREADED	1/4" NPT(2)	
K3	HYDRAULIC CONN.	THREADED	1/4" NPT(2)	
N1	INLET	FLANGED	18" ASA	
N2	OUTLET	FLANGED	18" ASA	CLASS #150 F.F.S.O.
N3	FLUSH OUTLET	FLANGED	3" ASA	CLASS #150 F.F.S.O.

TOLERANCES (UNLESS OTHERWISE SPECIFIED)	
FRAC. ±1/16	ANGLE ±1°
.X ±.1	
.XX ±.05	
.XXX ±.010	
<b>MATERIAL:</b> SST	
<b>DRAWN BY:</b> S. PERKINSON	
<b>DATE:</b> 04/20/2018	
<b>SCALE:</b> 1:22	<b>SHEET:</b> 1 OF 1

**TEKLEEN**  
Automatic Filters Inc.  
2672 S. LA CIENEGA BLVD.  
LOS ANGELES, CA 90034  
MAIN: (310) 839-2828  
FAX: (310) 839-6878

**TITLE:** ABW18-TP FILTER, ONE HOUSING, CUT DRAWING

<b>DRAWING NUMBER</b>	<b>REV</b>
ABW-18TP-CUT-02	N/A