

REVISIONS				
REV.	ZONE	DESCRIPTION	DATE	INITIAL
1	ALL	REMOVED FILTER EAR DIMENSIONS, CHANGED WORKING TEMP & PRESSURE TO DESIGN TEMP & PRESSURE	05/01/13	J.K.
2	7D	ADDED NOTE 1.	10/17/14	M.S.

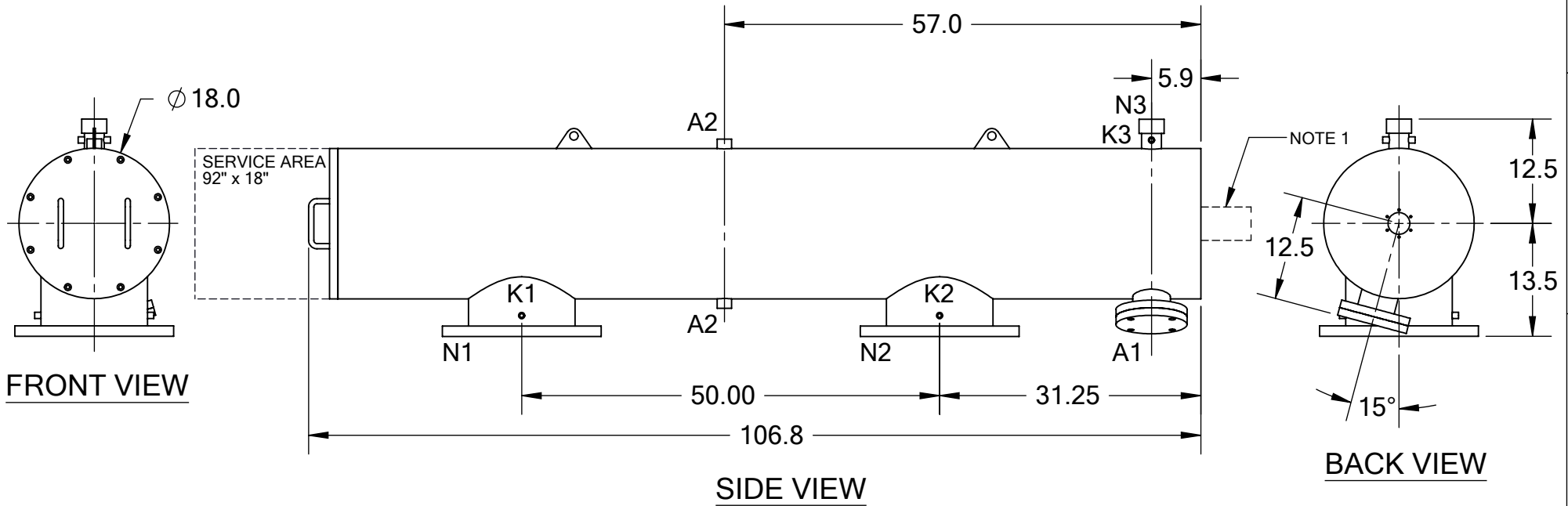

TECHNICAL DATA

FLOW RATE	MAX. 4,000 GPM (908 m ³ /hr)
SCREEN SIZE	___ MICRON
SCREEN AREA	12.5 SQ. FEET
DESIGN TEMPERATURE	160 °F
DESIGN PRESSURE	150 PSI
EMPTY WEIGHT	~850 LBS.
FULL WEIGHT	~1,300 LBS.

NOTES:

- PLEASE ALLOW ~20" ADDITIONAL TO INSTALL AND REMOVE THE PISTON ASSEMBLY TO THE BACKSIDE OF THE FILTER.

NOZZLE	CONNECTION	TYPE	SIZE	RATING
A1	SERVICE PORT	FLANGED	3.5" ASA	CL. #150 F.F. w/ Blind
A2	PRESSURE RELEASE	THREADED	1" NPT(2)	
K1	HIGH PRESSURE CONN.	THREADED	1/4" NPT(2)	CLASS #150 F.F.S.O.
K2	LOW PRESSURE CONN.	THREADED	1/4" NPT(2)	
K3	HYDRAULIC CONN.	THREADED	1/4" NPT(2)	CLASS #150 F.F.S.O.
N1	INLET	FLANGED	12" ASA	
N2	OUTLET	FLANGED	12" ASA	
N3	FLUSH OUTLET	THREADED	2" NPT	

TOLERANCES (UNLESS OTHERWISE SPECIFIED)

FRAC. ±1/16
.X ±.1
.XX ±.05
.XXX ±.010

ANGLE ±1°

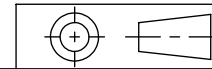

MATERIAL: SST

DRAWN BY: S. PERKINSON

DATE: 08/18/11

SCALE: 1:18

SHEET: 1 OF 1

TEKLEEN
Automatic Filters Inc.
2672 S. LA CIENEGA BLVD.
LOS ANGELES, CA 90034
MAIN: (310) 839-2828
FAX: (310) 839-6878

TITLE:
ABW12-LP FILTER,
CUT DRAWING

DRAWING NUMBER
ABW-12LP-CUT-01

REV
2