

REVISIONS				
REV.	ZONE	DESCRIPTION	DATE	INITIAL

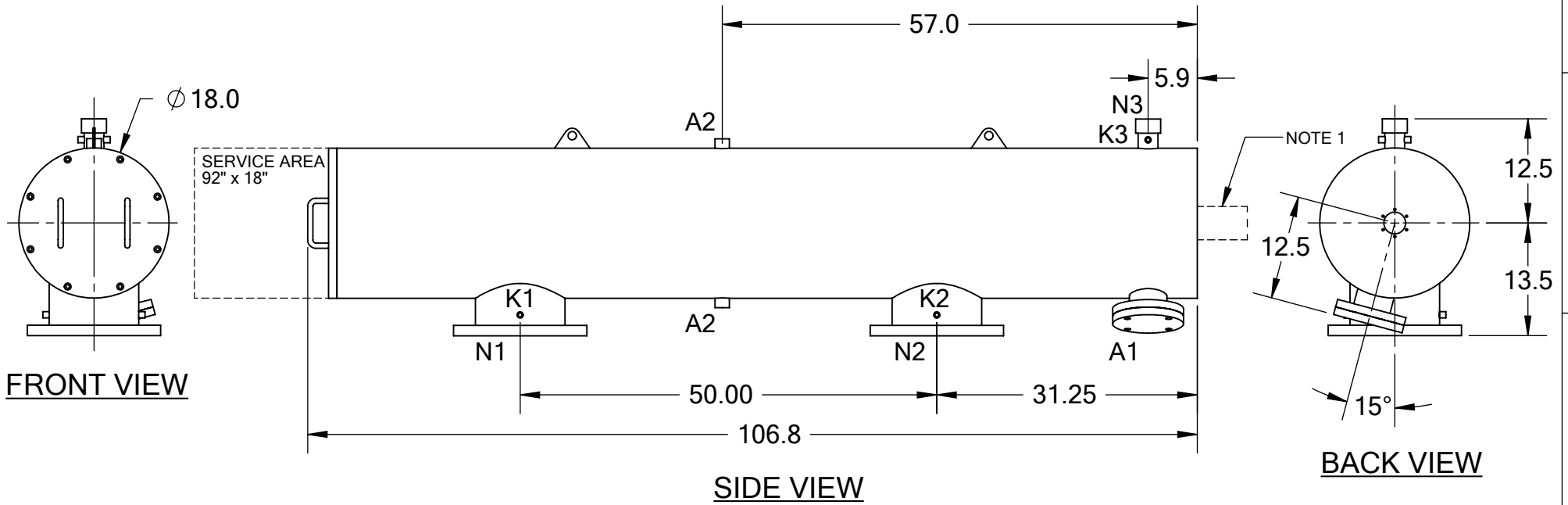

TECHNICAL DATA

FLOW RATE	MAX. 4,000 GPM (908 m <sup>3</sup> /hr)
SCREEN SIZE	___ MICRON
SCREEN AREA	12.5 SQ. FEET
DESIGN TEMPERATURE	160 °F
DESIGN PRESSURE	150 PSI
EMPTY WEIGHT	~800 LBS.
FULL WEIGHT	~1,200 LBS.

NOTES:

- PLEASE ALLOW ~20" ADDITIONAL TO INSTALL AND REMOVE THE PISTON ASSEMBLY TO THE BACKSIDE OF THE FILTER.

NOZZLE	CONNECTION	TYPE	SIZE	RATING	TOLERANCES (UNLESS OTHERWISE SPECIFIED)	 2672 S. LA CIENEGA BLVD. LOS ANGELES, CA 90034 MAIN: (310) 839-2828 FAX: (310) 839-6878
A1	SERVICE PORT	FLANGED	3.5" ASA	CL. #150 F.F. w/ Blind		
A2	PRESSURE RELEASE	THREADED	1" NPT(2)	CLASS #150 F.F.S.O. CLASS #150 F.F.S.O.	MATERIAL: SST	
K1	HIGH PRESSURE CONN.	THREADED	1/4" NPT(2)		DRAWN BY: M. SERRANO	
K2	LOW PRESSURE CONN.	THREADED	1/4" NPT(2)	DATE: 12/19/18		TITLE: ABW10-SLP FILTER, CUT DRAWING
K3	HYDRAULIC CONN.	THREADED	1/4" NPT(2)	SCALE: 1:18      SHEET: 1 OF 1		
N1	INLET	FLANGED	10" ASA	DRAWING NUMBER		REV N/A
N2	OUTLET	FLANGED	10" ASA	ABW-10SLP-CUT-01		
N3	FLUSH OUTLET	THREADED	2" NPT			